

MANUAL

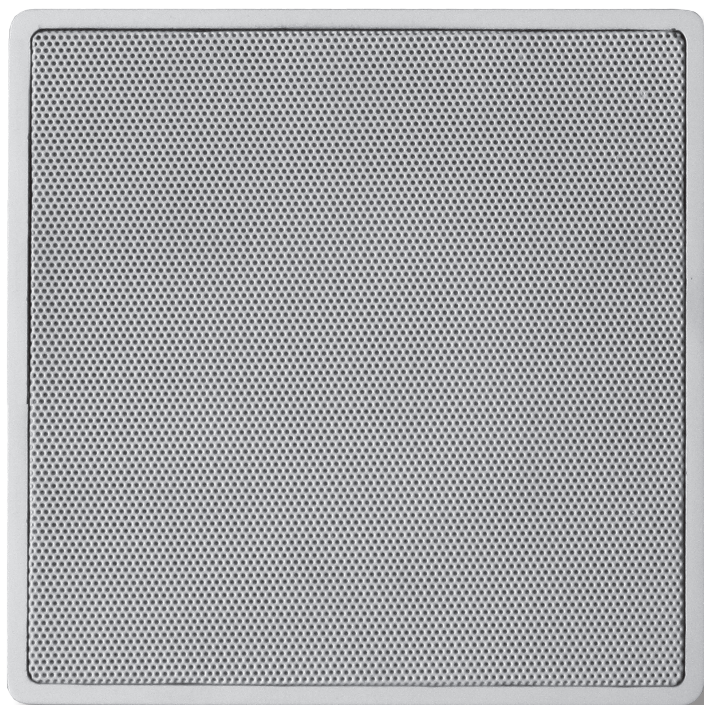

CMSQ108

Introduction

Please read this manual carefully before using the product. This will give you the necessary product and installation instructions to assure a seamless installation and non compromised overall sound quality.

Thanks for purchasing our APart CMSQ108 speaker. We have put great care and effort in the design in order to bring you high quality sound. The CMSQ108 is an elegant and very natural sounding in-wall/in-ceiling speaker. It easily outperforms many standard cabinet speakers, both in sound quality and appearance.

CMSQ108 has a nominal impedance of 8Ω , allowing you to connect up to 2 speakers in parallel per 4Ω stable amplifier channel. Easy to integrate in high-end audio chains, cinema surround systems or even high quality BGM systems, this speaker offers a soundstage, unheard in this price range.

Safety precaution

- Keep this manual for future reference.
- When making the hole in your mounting panel to mount the APart CMSQ108 speaker, make sure there is sufficient clearance behind the panel (no obstructions like A/C channels, power lines etc).
- Take care of your speaker wires, they should be free of damage. Damaged speaker wires might result in poor sound quality and can damage amplifiers.
- Only use accessories specified by the manufacturer
- Make sure the mounting panel can support the speakers weight.
- Use sufficient amount of speakers to avoid death-spots.
- No mains power shall be connected to the loudspeakers, doing so will damage the speaker.
- This apparatus should only be serviced by qualified personnel. If not warranty

might be void.

- Use cable of the right gauge, certainly for long runs.
- Use cables with clear color indication and maintain polarity throughout the whole system.
- Avoid loud feedback from microphones, this can damage your speaker.
- Please check the units condition after unpacking. If the outside of the carton box has been damaged, inform your shipper immediately.
- Take notice that this speaker is meant for indoor use only!

Features and benefits

Turn your living room walls into a wall of sound, at the highest possible hifi standards, exactly there where you feel at home. CMSQ108 features a 5.5" bass-mid speaker with a paper/Kevlar sandwich cone and a low loss rubber surround. This guarantees highest possible definition and lowest sound coloration. High frequencies are covered by a tiltable 1 inch silk dome tweeter, carefully matched and tuned to deliver an amazing and detailed sound without the harshness usually reproduced by cheap metal alloy domes.

Due to the narrow visible mounting flange and paintable detachable steel grilles, the speakers can be integrated very discretely in even the most demanding environments, in your living room, connected to your multiroom system, hifi or cinema surround audio system... side by side to your flatscreen TV.

Mounting is easy and straightforward. The speaker clamps accept wall thickness of 0 to 30 mm. By using our optional in-wall mounting cabinet, you can install the speaker even in solid brick walls. Speaker cables are securely clamped in the gold plated cable connectors, accepting thick speaker cables up to 6 mm².

The CMSQ speakers are not magnetically shielded, this is not necessary unless you

install them close to a CRT screen. Flatscreens, the ideal partners for the CMSQ speakers, are insensitive to magnetic fields. Instead we have invested in solid gold plated speaker wire terminals, a carefully tuned crossover with high quality components, solid steel speaker grille and of course top notch quality drivers. You will hear the difference!

Recommended applications

- Multi Room audio systems.
- Home Theatre systems.
- Lounges, Bars, Boutiques.
- Board rooms & Offices.
- Convention Centres, Hotels, sports facilities.

Speaker positioning

Ideally, you should position the speakers on ear level or above, never below. When the speakers are positioned far above the listening position (more than 60 cm), pivot the tweeter and aim it towards the listening position.

Avoid the presence of wall corners, because these will augment reflections, causing an unstable stereo image and boomy bass.

If possible, mount the speakers close to the sides of your flatscreen TV, about 1.5 meters or more apart from each other, depending on screen size and listening distance. In general, the listening position and the left and right speaker should form an equilateral triangle and the speaker should be positioned halfway the screen or slightly higher.

For hifi setups, mount the speakers between 1/2 and 2/3 of total wall height, for walls up to 3 meters height, and stay at least 50 cm clear of adjacent walls. You can also mount the speakers in a ceiling if necessary.

Speaker mounting instructions

Recommended minimum installation volume is 4 liters. By using our optional in wall speaker frame/cabinet, the optimum cabinet volume is guaranteed. There is no upper volume limit. When the speaker is installed in a space with hard materials such as bricks or concrete, additional cavity damping may be required. Suitable materials are mineral insulation materials such as Rockwool or BAF (bonded acetate fiber). Hard foam materials such as polystyrene and other polyfoams are not suitable. Make sure that the used damping materials meet your local fire and building requirements. Check that there are no obstacles such as electrical tubes, wires or other pipes behind the speaker. Make sure the area behind the speaker is free of small particles such as small stones. These particles can damage the vented magnet system of the speaker. In cases of doubt, protect the rear of the speaker with a small amount of BAF wadding.

To make grille removal easier, a special grille removal tool is supplied with the speakers. Insert the tool in a corner of the grille and gently pull the grille out. Repeat this step on all corners until the grille is entirely free. Do not attempt to pull out the grille by pulling one side of the grille, this may cause damage to the grille or the frame. Keep the tool at hand in case you need to remove the grille. Be extra careful when positioning the tweeter: do not touch the tweeters membrane. Keep the tilt angle within a range of 10 degrees from the neutral position.

Using the cutout template

Note: when making the hole in your mounting panel, double check if there are no cables or any other obstructions behind the mounting panel. Cutting the mounting panel without this check might result in damaged infrastructure or power lines.

1.

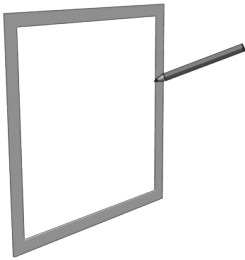

2.

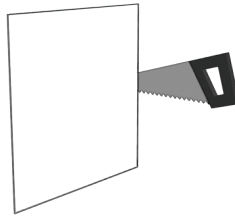

3.

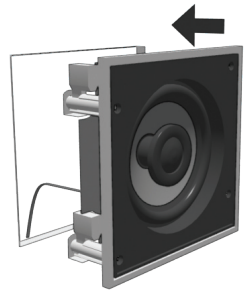

4.

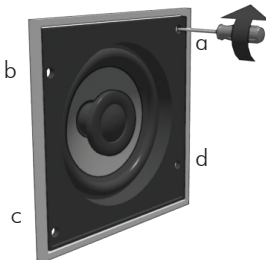

5.



The CMS5BBI built-in box

Because we want to make the lives of installers easy APart offers a built-in box for our square CMSQ108 speaker. The box is insulated to prevent resonance and is custom-built. Once again, APart proves to be your one stop solution for all your installed sound projects!

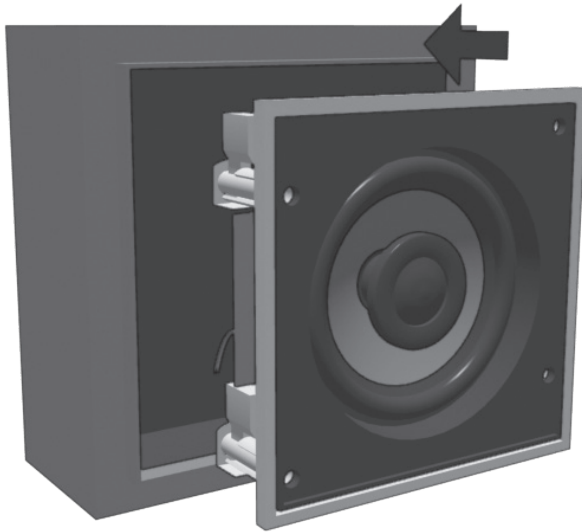

Connecting the speaker

Use the correct polarity when daisy chaining speakers! When a mistake occurs in your daisy chain, it can severely impact speaker performance as there will be audio-cancellation.

The daisy chain options are endless and the setup will depend on the capabilities of your amplifier. Make sure when daisy chaining speakers that the total impedance is not lower than the lowest specified impedance of your amplifier. Not following this rule might result in distorted sound and might even damage your amplifier.

Series wiring speaker diagram:

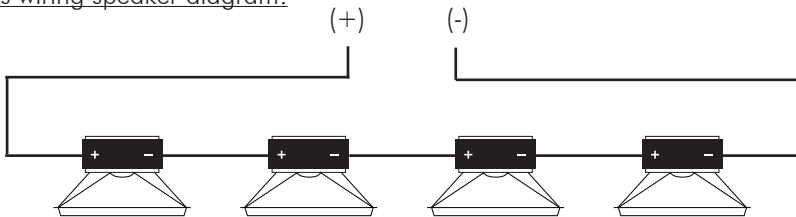

$$\text{Total resistance} = R1 + R2 + R3 + R4 + \dots$$

Parallel wiring speaker diagram:

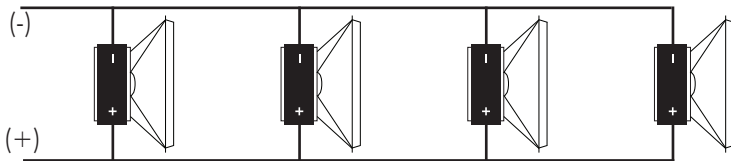

$$\text{Total resistance} = \frac{1}{1/R1 + 1/R2 + 1/R3 + 1/R4 + \dots}$$

R1 = Resistance of speaker 1

R2 = Resistance of speaker 2

R3 = Resistance of speaker 3

R4 = Resistance of speaker 4

Specifications

Speaker type	in-wall/in-ceiling, square mounting frame, two way hifi.
Recommended amplifier power	15 to 120 watts per channel
Rated RMS power	50 W
Nominal impedance	8 Ohms
Frequency range	50* – 25000 Hz
Sensitivity	87 dB spl (2.83V/1m)
Dispersion at 1 kHz, 2 kHz, 4 kHz, 8 kHz	180, 170, 120, 80
Crossover frequency and slope	3000 Hz, 12 dB/oct
Bass-mid speaker	5.5" paper/Kevlar sandwich cone
Tweeter	1" soft dome, pivotable within approx 10 degrees in all directions
Chassis color	White
Chassis type	Plastic
Grille material	Painted steel
Removable grille	Yes
Fixing type	dog-ears
IP classification	60
Dimensions outside H x W	167 x 167 mm
Mounting depth	73 mm
Total depth	80 mm
Cutout dimensions H x W	145 x 145 mm
Speaker weight	1360 g

Options: solid-wall mounting frame-cabinet/custom colour (CMS5BBI / PAINTCM)

* low frequency limit depends on room size, backspace volume, damping, proximity of adjacent walls etc...

Polar diagrams

Polar diagram 1000 Hz

Polar diagram 2000 Hz

AP
1000Hz

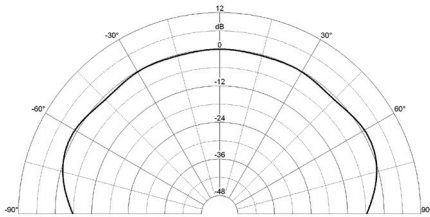

AP
2000Hz

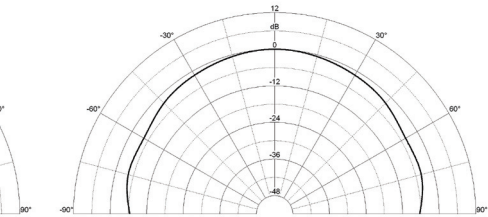

CLIO

Polar diagram 4000 Hz

Polar diagram 8000 Hz

AP
4000Hz

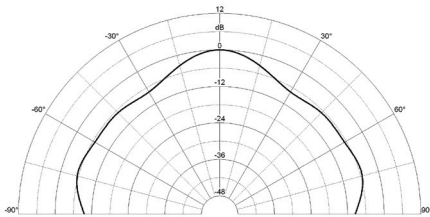

AP
8000Hz

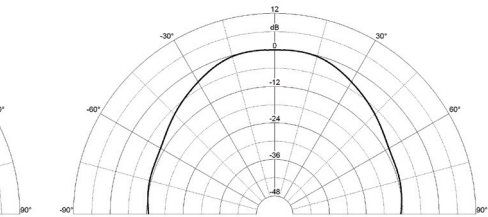

CLIO

Technical drawing with measurements

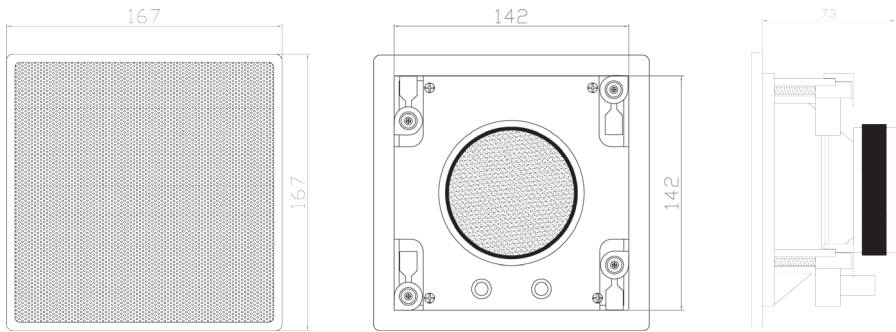

Warranty info

APart-Audio warrants this product to be free of defects in material and workmanship for a period of one year for parts and for a period of one year for labor from the date of original end-user purchase. This warranty is valid only for the original end-user and cannot be transferred.

During the warranty period APart-Audio or one of its authorized service partners shall either repair or replace any product, free of charge, that proves to be defective on inspection by APart-Audio or its authorized service representative.

This warranty does not include, damages or product faults due to abuse, misuse or faulty installation.

ANY SUGGESTION?

***They are well appreciated and eventually rewarded!
Send your ideas or suggestions to***

suggestions@apart-audio.com

Company names, product names, and names of formats etc. are the trademarks or registered trademarks of their respective owners.

© 2011 APart-Audio specifications subject to change without notice.

developed by

***Audioprof nv
Industriepark Brechtsebaan 8 bus 1
2900 Schoten
Belgium***

